

**PRODUCTION METHODS OF DIESEL FUEL
WITH THE IMPROVED ECOLOGICAL PROPERTIES
ON JSC "SALAVATNEFTEORGSINTEZ"**

R.R. Usmanov

JSC "Salavatnefteorgsintez"

L.K. Minibaeva, O.A. Baulin, M.N. Rahimov

Ufa State Petroleum Technological University

email: linchik88@yandex.ru

The way which has received a wide circulation of improvement of quality of diesel fuel is use of additives of a various functional purpose. The greatest practical importance possess cetane enhancing additives, greasing additives and additives improving low-temperature properties capable to provide stable work of diesel engines. Taking into consideration that fact, that now in Russia large-scale manufacture of additives to diesel fuels practically is absent, and the requirement for them is satisfied at the expense of purchases on import, working out of domestic technologies for reception of effective additives is now actual. It is spoken about features of manufacture of additives to the diesel fuel, meeting modern and perspective requirements.

1. Introduction

Manufacture of high-quality diesel fuels is impossible without addition of additives with different functional purposes. Injection of wear-resistant, cetane rise, depressant and other additives in diesel fuel structure solves a problem of improvement of their operational properties. In this case process of fuel combustion is improved, that allows lowering its consumption, prolonging service life of the engine and improving its ecological characteristics. There is much attention to solution of this problem abroad, while in our country interest to this area appeared not so long ago.

Till now Russian petroleum refinery bought additives abroad, with stable large-tonnage manufacture it is undesirable, because in this case the whole manufacture of modern fuels is dependent on a policy of the foreign companies. Home industry has necessary raw and technological possibilities for manufacturing its own additives with different functional purposes. And the demand for them, depending on volume of fuel manufacture and average working concentration of additives, is estimated on the level 800-1000 t/year, and in the long term – 7-10 thousand t/year.

The purpose of study was development of dopes and additives for manufacture of diesel fuel with the improved ecological indicators at JSC "Salavatnefteorgsintez"

with the use of the products developed by this company.

According to this purpose the following problems have been solved in research:

- development of cetane enhancing additives;
- development of greasing additive;
- choosing the additives improving low-temperature properties of diesel fuel;
- development of additives improving ecological and operational characteristics of diesel fuel;
- studying the impact of the developed additives on physical and chemical properties of diesel fuel sample.

2. Bibliographic study

Now the largest environmental problem is the reduction of harmful substances into the environment, among which the most prevalent is the exhaust gases from internal combustion engines [1].

The typical structure of the harmful substances contained in exhaust gases is listed in Table 2.1 [2-5, 7].

Table 2.1

Typical structure of the harmful substances contained in exhaust gases

Type of fuel	Emissions of harmful substances, g/kg fuel						
	CO	HC	NO _x	SO _x	Aldehyde	Soot	All
Gasoline	465,5	23,3	15,8	1,9	0,9	1,0	508,5
Diesel	20,8	4,2	18,0	7,8	0,8	5,0	56,5

From Table 2.1 it can be seen that the engines running on diesel fuel have a number of advantages over those running on petrol. The exhaust gases of the diesel engine contain less carbon monoxide (CO), hydrocarbons (HC) and aldehydes, and the total emissions are approximately 10 times less [6, 7].

The main shortcomings of diesel engines are the large emissions of soot, sulfur oxide (SO_x) and nitrogen oxides (NO_x).

The need to improve the characteristics of motor fuel is caused by the increased requirement for mineral oil of new quality in connection with extending mechanisation, rigid requirements to environment protection, and the economy of the natural resource, oil.

One of the ways to decrease the harmful emissions into the environment is the manufacture of motor fuel with improved ecological indicators, and the most widespread process directed at the improvement of the quality of diesel fuel is hydrotreating.

As a result of this process there is a decrease in the levels of sulphur and aromatic hydrocarbons in motor fuel.

For example, the sulphur level in diesel fuel can decrease to 0,005 % by mass.

And the level of nitrogen is reduced 2-3 times – oxygenic connections and aromatic hydrocarbons also decrease.

The tendency of decrease in the level of sulphurous connections and aromatic hydrocarbons is traced in specifications of diesel fuel of different countries.

Last year, European standard EN 590 was changed: the maximum sulphur level is lowered to 0,035 % by weight (Euro-1), to 0,005 % by weight (Euro-2) and less (Euro-3,4), cetane number is increased by 45 to 51 units (in the long term to 54 units), restrictions on density and viscosity, and also new indicators have been added – the level of polycyclic aromatic hydrocarbons, the oxidizing stability, and lubricating ability.

Development of diesel fuel quality requirements per the standard EN 590 is resulted in Table 2.2.

Table 2.2

Development of diesel fuel quality requirements per the standard EN 590

Indicators	EN 590		
	2000 year	2005 year	2008 year
Commissioning	2000 year	2005 year	2008 year
Mass fraction of sulphur, %, maximum	0,035	0,005	0,003
Cetane number, minimum	51	53	54-58
Density at 15 °C, kg/m ³	820-845	825-845	825-830
Kinematic viscosity at 40 °C, mm ² /s	2,0-4,0	2,0-4,0	2,0-4,0
Fractional structure: 95 % are overtaken to, °C	360	340-360	340-350
The maintenance of polycyclic aromatic hydrocarbons, %, maximum	11	6	4
The lubricating ability, the corrected diameter of a stain of deterioration, micron, no more	460	460	460
Oxidizing stability, g/m ³ , maximum	25	25	25

As listed in Table 2.2, European standard EN 590 provides further restriction of the levels of sulphur and aromatic hydrocarbons.

However, there is a deterioration of the lubricating ability of the fuel, which leads to higher wear of the diesel engine under operating conditions.

The most widespread way to increase the lubricating ability of diesel fuel is the introduction into its structure of special antiwear additives.

We carry out research on development of multipurpose additives for diesel fuel on the basis of by-products of petrochemical manufactures, JSC "Salavatnefteorgsintez"

3. Experimental technics

3.1. Main purposes and research problems

The purposes of study were:

- development of additives and additives for diesel fuel manufacture with the improved ecological characteristics on JSC "Salavatnefteorgsintez";
- maximum use of products developed by JSC "Salavatnefteorgsintez", as initial components for synthesis of additives.

According to the purpose in view the following problems have been solved in research:

- development of cetane enhancing additives (CEA);
- development of greasing additives;
- Researches of the additives improving low-temperature properties of diesel fuel;
- research of the additives improving ecological and operational characteristics of diesel fuel;
- studying the impact of the developed additives on physical and chemical characteristics and operational properties of diesel fuel.

3.2. Objects of researches

The objects of researches were fuel compositions which represented base fuel containing various additives. Test of diesel fuel of JSC "Salavatnefteorgsintez" manufacture, which physical and chemical properties are presented in Table 3.1, was used as base test.

Table 3.1

Physical and chemical properties of diesel fuel

Parameter	State Standard 305-82	Value
1. Cetane number	No less 45	51
2. Fractional composition, °C – 50 % drop point – 96 % drop point	No more 280 No more 360	260 352
3. Cinematic viscosity at 20 °C, mm ² /sec	3,0-6,0	3,9
4. Setting point, °C	No above –10	–13
5. Cloud point, °C	No above –5	–6
6. Flash point in an close crucible, °C	No lower 62	69
7. Sulphur content, %	No more 0,2	0,1
8. Sour sulfur content, %	No more 0,01	0,001
9. Hydrogen sulphide content, %	absent	absent
10. Test for a copper plate	stand	stand
11. Content water solubility acids and alkali	absent	absent
12. Concentration of actual pitches, mg/100cm ³	No more 30	1,0
13. Acidity, mg KOH/100 cm ³	No more 5	absent
14. Iodine number, g iodine /100 g product	No more 6	1
15. Filtration factor	No more 3	1,0
16. Maintenance of mechanical impurity	absent	absent
17. Density at 20 °C, kg/m ³	No more 860	831

Technical rapeseed oil (RO) of Birsky commercial farm was also an object of our researches. RO represents a mix of mono-di-and triglyceride, which contains molecule of various fat acids in its structure. Acylglyceride, in its turn, contains a molecule of the various fat acids, connected with a molecule of glycerine C₃H₅(OH)₃ in its structure. Chemical structure of molecules of fat acids differ from each other only by the content of carbon atoms and level of saturation of fat acid. That's way plant oils properties are mostly defined by the content and structure of fat acids forming triacylglyceride.

Usually they are saturated and nonsaturated (with one-three double linkages) fatty acids with even number of carbon atoms (mainly C_{16} and C_{18}). Moreover plant oils have small amounts of free fatty acids with odd number of carbon atoms (from C_{15} to C_{23}). Molecular weight of RO is 900 g/mole.

Low volatility and high viscosity of plant oils exclude their use in petrol engines. However they can be used successfully as fuel for diesel engines. Rather low thermal stability of plant oils, acceptable temperature of their spontaneous ignition equal 280-320 °C and a bit higher than temperature of spontaneous ignition of diesel fuel 230-300 °C help to it.

Furthermore, cetane number of different plant oils changes within the range from 33 to 50 points, that is comparable with cetane number of diesel fuels. Rapeseed oil is high ecofriendly raw material for biofuels manufacture. Oxygen contained in oil allows to considerably reduce emissions of harmful substances in atmosphere – hydrocarbons CH_x and soot. Reduction of burning temperatures at diesel engine work on this biofuel is accompanied by reduction of nitrogen oxide NO_x emission. Rapeseed oil practically does not contain sulphur compounds that leads to absence of its oxide SO_x (sulphurous gases and acids formed of them) in the exhaust gases (EG). In RO there are no the polycyclic aromatic hydrocarbons, usually contained in EG of diesel engines and presenting carcinogens, causing oncological diseases. All above-stated allows to improve essentially ecological characteristics of transport diesel engines by running on RO.

Use of plant oils in the pure state as fuel for diesel engines is restrained because of high viscosity and density, carbonization on sprays of atomizers and other details forming the chamber of combustion. The increase carbonization is promoted by the presence of resinous substances in plant oils, i.e. their raised coking efficiency.

Dissimilarity of physical properties of RO from properties of standard diesel fuels influences operating processes of diesel engines. First of all it concerns processes of fuel feed and air-fuel mixing.

Thus, high density and viscosity of RO, put into combustion chamber by regular system of diesel engine fuel feed, are the reasons of increase of RO cyclic giving and its hour expense in comparison with diesel fuels in accordance with State Standard 305-82. Because of raised viscosity of RO fuel throw is increased; part of fuel gets on the walls of combustor chamber; part of volume air-fuel mixing is reduced. Entering angle of a

fuel flare decreases and fineness spraying worsens – average diameter of drops increases. The raised superficial tension of RO raises its heterogeneity spraying.

As it is noted above, plant oils differ by the raised viscosity, that is more than viscosity of standard diesel fuels. During interesterification of plant oils acylglyciride are split on smaller molecules, that's why viscosity of received ethers is less than viscosity of initial oil.

In researches technical RO was used as a base component, physical and chemical properties of which are shown in Table 3.2; a technical product on a basis of aliphatic alcohols was used as an etherify component.

Table 3.2

Physical and chemical properties of rapeseed oil

Parameter	Value
1. Cinematic viscosity at 20 °C, mm ² /sec	79
2. Setting point, °C	-10
3. Cloud point, °C	-5
4. Flash point in an close crucible, °C	100
5. Test for a copper plate	stand
6. Content water solubility acids and alkali	absent
7. Maintenance of mechanical impurity	absent
8. Density at 20 °C, kg/m ³	914
9. Iodine number, g iodine /100 g product	106
10. Acid number, mg KOH/ g	5,5

As an initial component for synthesis of additives distillation residue of butyl alcohol (DRBA) manufactured by JSC "Salavatnefteorgsintez" are used.

DRBA represents a mix of aliphatic alcohols with a number of carbon atoms eight and more, carboxylic acids. Average componental structure of DRBA is presented in Table 3.3.

Table 3.3

Physical and chemical properties of DRBA

Parameter	Value
1. Fractional composition: – initial boiling temperature	180
– 50 % drop point	215
– 96 % drop point	242
– final boiling temperature	245
2. Cinematic viscosity at 20 °C, mm ² /sec	5,05
3. Setting point, °C	lower –70
4. Cloud point, °C	–69
5. Flash point in an close crucible, °C	64
6. Sulphur content, %	absent
7. Sour sulfur content, %	absent
8. Hydrogen sulphide content, %	absent
9. Test for a copper plate	stand
10. Content water solubility acids and alkali	absent
11. Concentration of actual pitches, mg/100cm ³	73
12. Acidity, mg KOH/100 cm ³	45,5
13. Iodine number, g iodine /100 g product	23,2
14. Filtration factor	3,8
15. Maintenance of mechanical impurity, %	absent
16. Density at 20 °C, kg/m ³	880

Table 3.4

Middle component composition DRBA

Component	Content, % mass.
isobutanol	0,8
n-butanol	1,3
isopentanol	3,6
isoheptanol	4,7
dimethylcyclohexanol	8,5
isoostanol	34,3
butyl butyrate	0,8
dibutoxybutane	37,1
polybutoxybutane	8,9

3.3. Methods of researches

3.3.1. Researches of greasing ability

Researches of greasing properties of fuel compositions were done by the method developed on Chair of technology of oil and gas USPTU. The method is based on State Standard 9490-75 «Liquid and plastic lubricant materials. A method of definition of greasing properties by the four-ball car (FBC)».

The friction knot in FBC represents a pyramid of four balls contacting with each other (diameter $12,70 \pm 0,01$ mm), made of steel IIIХ-15 in accordance with State Standard 801-78. Three bottom balls are fixed motionlessly in a cup of the car with the examined mineral oil. The top ball – fixed in a spindle of the car, rotates concerning three technics – bottom ones under the set loading with frequency of rotation 1460 ± 70 rpm. The scheme of knot of friction FBC is resulted on Fig. 3.1.

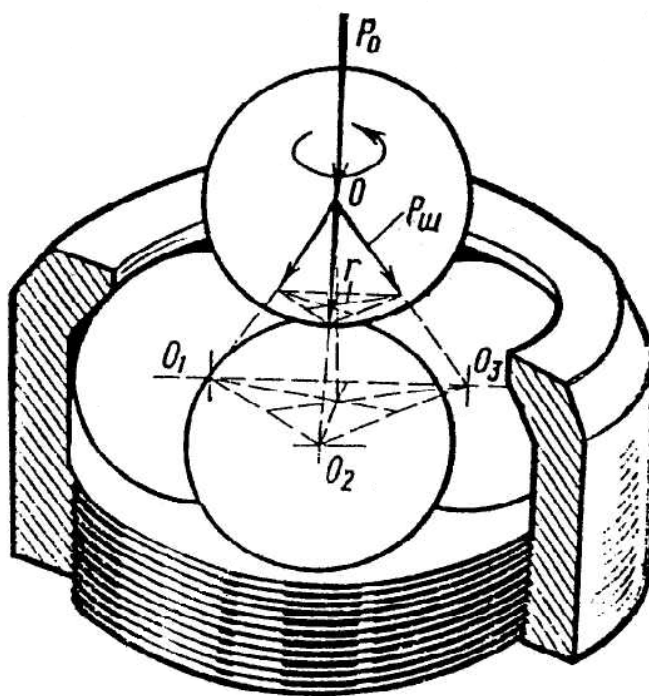

Figure. 3.1. The scheme of knot of friction FBC

During the researches of greasing ability of fuel compositions the following conditions were taken: applied loading 100 H, time of test 60 minutes, temperature 20 °C. Criterion of greasing ability was average value of WSD of each three bottom balls measured along a direction of deterioration and perpendicular to it, measured on a microscope with 30-fold increase within 0,01 mm.

3.3.2. Standard methods of researches of physical and chemical properties of diesel fuels

During the work standard methods of researches of definition of physical and chemical properties of mineral oil also were used. The list of taken standard methods of researches is shown in Table 3.6.

Table 3.6

The Standard methods of researches used in work

Parameter	
Determination of cinematic viscosity	State Standard 33-82
Determination of setting point	State Standard 20207-74
Determination content of aromatic hydrocarbons	State Standard 6994-74
Determination of density	State Standard 3900-85
Determination of filtration factor diesel fuel	State Standard 19006-73
Test for a copper plate	State Standard 6321-79
Determination content of water in petrochemicals	State Standard 6307
Determination content of mechanical impurity in petrochemicals	State Standard 6370-83
Determination of flash point in an close crucible	State Standard 6356
Determination of Fractional composition	State Standard 2177-82
Determination of actual pitches in petrochemicals	State Standard 8489
Determination content sulphur in petrochemicals	State Standard 19121-73
Determination of cetane number	State Standard 3122
Determination of Iodine number	State Standard 2070
Determination of acidity	State Standard 5985
Determination of cloud point	State Standard 5066
Determination of resin acids	State Standard 1770-74

4. Result and discussion (Dopes to diesel fuel)

4.1. Synthesis of the promoter of diesel fuel ignition on a basis alkylnitrate

We have synthesised an additive ignition promoter by nitration of technical product on a basis of aliphatic alcohols C_8+ (DRBA), manufactured by JSC "Salavat-nefteorgsintez", by technical nitric acid.

Nitration was done by gradual adding (during 2 hours) of nitrating mixes (63% nitric acid and 93 % sulfuric acid) to DRBA. These were mixed at temperature of 8-18 °C.

Then the derived product was repeatedly washed and leached by NaOH. The derived product was given code CEA-1.

Laboratory installation is presented in Fig. 1.

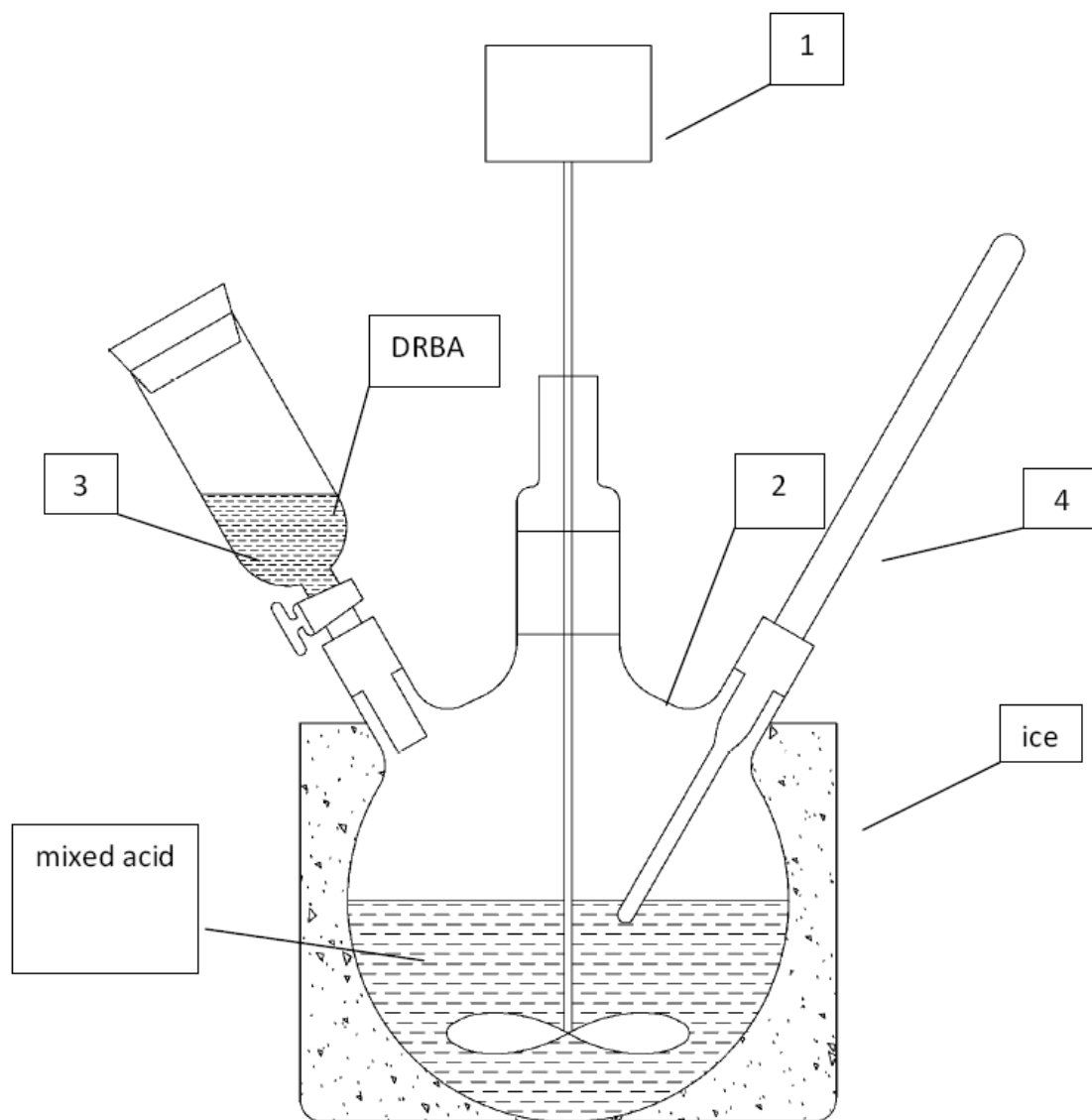

Figure 4.1. Laboratory installation synthesised an additive ignition promoter:

1 – mixer; 2 – three-neck flask; 3 – volume buret; 4 – thermometer

4.1.1. The impact of CEA-1 additive on cetane number of diesel fuels

The researches of impact of the received product on cetane numbers of diesel fuel test were done. The results of research are shown in Figure 4.2.

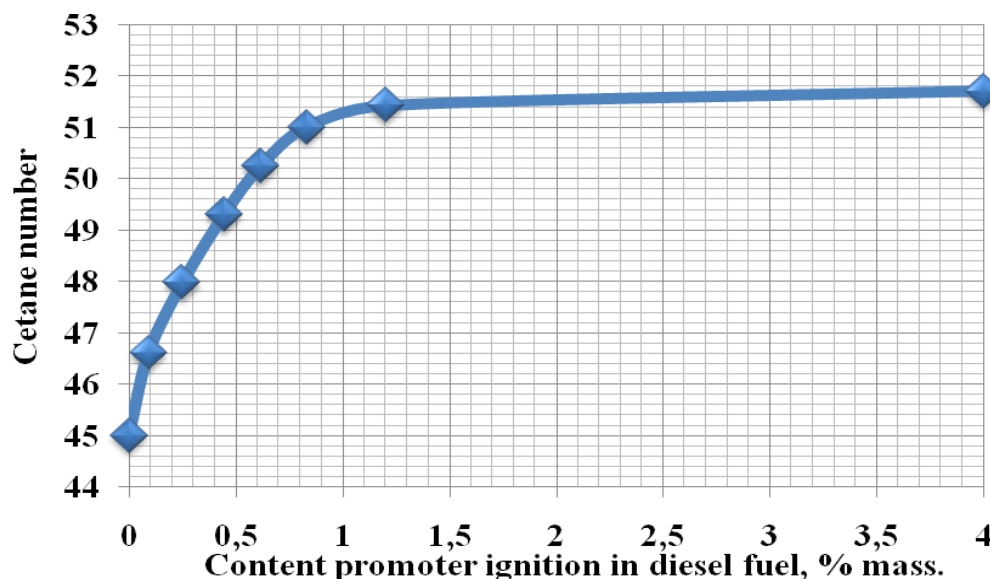

Figure 4.2. Influence CEA-1 on cetane number diesel fuel

As it is seen from Fig. 4.2 with the increase in content of developed additive ЦИИИ-1 there is the increase in cetane numbers of diesel fuel. The increase of cetane numbers by 6 points is observed at the content of 0,8 % of weights. With the further increase of CEA-1 additive content in diesel fuel the increase of cetane number considerably slows down.

Further researches consist in concentration of active part of additive CEA-1 for the purpose of its specific flow reduction.

4.1.2. The impact of CEA-1 additive on lubricating properties of diesel fuel

It is known from literature that nitro compound can have negative impact on diesel fuel lubricity. That's why the researches were conducted on the impact of developed ignition additive on diesel fuel lubricity.

The dependence of wear scar diameter (WSD) on the content of additive is shown in Fig. 4.3

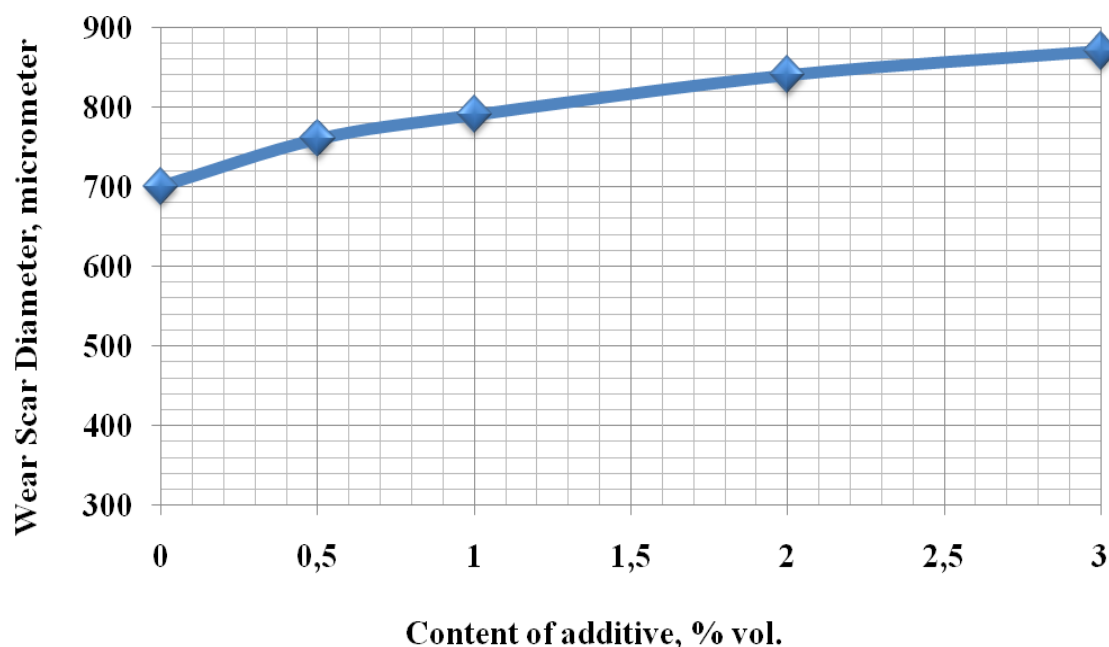

Figure 4.3. Influence CEA-1 on cetane number diesel fuel

It is seen from Fig. 4.3, that injection of the developed additive in structure of diesel fuel leads to deterioration of its greasing ability.

Hence, using the developed promoter of ignition it is necessary to modify the dosage of wear-resistant additive.

4.1.3. The results of researches

After the researches there was shown a possibility of synthesis of additive-promotor of ignition diesel fuel by the nitration of technical product on a basis of aliphatic spirits C_{8+} . The additive received in laboratory conditions has shown high efficiency.

On the one hand the increase of content of additive CEA-1 in diesel fuel leads to increasing of its CN, on the other hand, additionally to this, the decrease of greasing ability of DF is observed.

Thus, it is necessary to modify the dosage of additive CEA-1 taking into account necessary level of CN increase and admissible WSD decrease.

Table 4.1

Physical and chemical properties of initial diesel fuel containing 0,8 % mass additives CEA-1

Parameter	State Standard 305-82	Value	
		DF	DF+0,8% mass.
1. Cetane number	No less 45	45	51
2. Fractional composition, °C: - 50 % drop point - 96 % drop point	No more 280 No more 360	260 352	258 350
3. Cinematic viscosity at 20 °C, mm ² /sec	3,0-6,0	3,9	3,3
4. Setting point, °C	No above -10	-12	-12
5. Cloud point, °C	No above -5	-6	-6
6. Flash point in an close crucible, °C	No lower 62	69	64
7. Sulphur content, %	No more 0,2	0,1	0,1
8. Sour sulfur content, %	No more 0,01	0,001	0,001
9. Hydrogen sulphide content, %	absent	absent	absent
10. Test for a copper plate	stand	stand	stand
11. Content water solubility acids and alkali	absent	absent	absent
12. Concentration of actual pitches, mg/100cm ³	No more 30	1,0	1,0
13. Acidity, mg KOH/100 cm ³	No more 5	absent	1,0
14. Iodine number, g iodine /100 g product	No more 6	1,0	0,6
15. Maintenance of mechanical impurity, %	No more 3	1,0	absent
16. Density at 20 °C, kg/m ³	860	831	806

As it is seen from data in Table 4.1 with the content 0,8 % mass of CEA-1 in DF, there are no changes in its physical and chemical characteristics exceeding State Standard 305-82.

Taking into consideration economic and operational reasons 0,8 % of additive mass is maximum.

However use of additive worsens greasing ability of fuel, therefore it is necessary to increase a dosage of wear-resistant additive.

Further researches consist in concentration of active part of developed additive; in achieving its physical and chemical properties to level of a final product; in improving the technology of developing of effective ignition promotor on the basis of CEA-1 additive, without loss of greasing ability.

4.2. Synthesis of wear-resistant additives on the basis of fatty acids

We develop three wear-resistant additives which were given code AW-1, AW-2, AW-3. Additive AW-1 represents a product containing naphthenic acids C_{17} - C_{22} . Additive AW-2 represents a product containing nonsaturated carboxylic acids. Additive AW-3 represents a product containing a mix of pitch acids and naphthenic acids C_{17} - C_{22} . Dependence WSD on the content of additives in test DF is presented in Fig. 4.4.

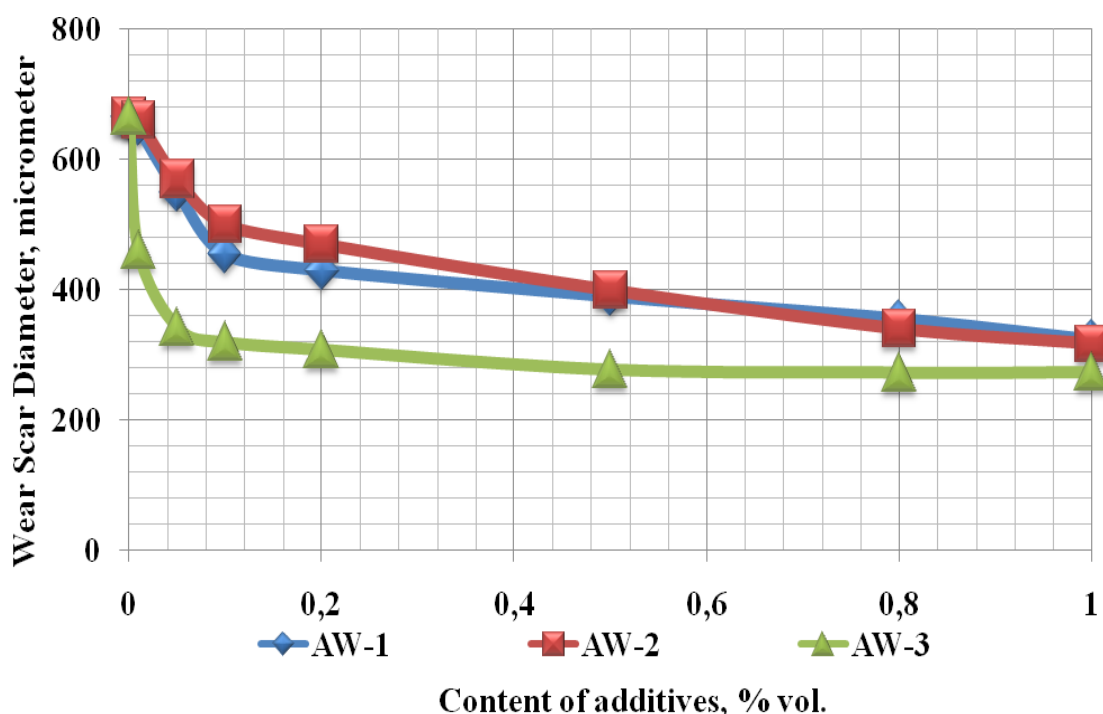

Fig. 4.4. Dependence WSC on content of dopes in diesel fuel

As it is seen from Fig. 4.4 maximum decrease of WSD is observed in case of using of AW-3 additive. With 0,01 % content of this additive in diesel fuel test WSD decreases to 31 %.

With increase in the content of additive in DF WSD decreases, i.e. increase of greasing ability. With 0,1 % mass content of additives AW-1, AW-2, AW-3 WSD decreases to 31, 25 and 52 % respectively.

4.3. Synthesis of succinimide-based multifunctional additive

Advantages of using succinimide additives in fuels[12-16]:

1. reduction of weight of adjournment in carburettors in average on 60 %;
2. reduction of weight of adjournment on intake valves on 70 %;
3. reduction of fuel consumption on 3 %;
4. decrease of content of WITH and hydrocarbons in the fulfilled gases on 50-60 %, and oxide nitrogen – on 20 %.

4.3.1. Synthesis of succinimide oligomer ethylene

On chair TNG UGNTU the additive on a basis of succinimide oligomer ethylene has been developed.

For synthesis of succinimide oligomer ethylene they used low-molecular polyethylene.

They put oligomer ethylene (OE) and maleic anhydride (MA) into a synthesis reactor. Reactionary substation is intensively mixed, first at temperature 60 °C during 1,0 hour, then reactionary substation is mixed at temperature 260-280 °C during 5,5 hours. After that they put the received succinimide oligomer of ethylene and dilute in the recycled fulfilled oil with necessary weight relation, heat to temperature 60 °C and add ПЭПА during 2 hours by drops. Then they raise temperature to 150 °C and do synthesis within 3 hours deleting water formed in reaction, in addition barbotage reactionary mix. 74 % of alkenylsuccinimide is received. The received product is cooled down to temperature 80 °C and filtered.

Table 4.2

Physical and chemical properties of succinimide additive

Parameter	Norms	Value
1. Color, under iodimetric scale, mg I ₂ /100 cm ³ , no more	160	140
2. Cinematic viscosity at 100 °C, mm ² /sec, no more	120	61,5
3. Base number in KOH per 1 g of the additive, no less	20	49,8
4. Acid number, mg KOH per 1 g of the additive, no more	4	0,29
5. Nitrogen content, %, no less	2,4	3,02
6. Mechanical impurities content, %, no more	0,06	absent
7. Water content, %, no more	0,1	absent

Parameter	Norms	Value
8. Corrosion of base oil M-11 (TU 38-101523-80) with 1,5 % succinimide additive LAG-03 and 1,2 % of additive DF-11, g/m ² , no more	10	5
9. Detergent property according PZV of base oil M-11 with 1,5 % succinimide additive LAG-03 and 1,2 % of additive DF-11, in points, no more	1	0,5
10. Active substance content, %, no more	40	49,8
11. Free polyamints content, %, no more	0,8	0,22
12. Flash point in an open crucible, °C, no less	160	197

4.3.2. Estimation of dispersive – stabilizing properties of engine oils

In Table 4.3 there are dispersive-stabilizing properties of engine oils of an additive on a basis of succinimide and industrial additive C-5A

Table 4.3

Dispersive-stabilising properties of motor oil

Additives	Oil Content, % mass.	Result estimation of oil with additive		
		C _t , %		D ₂₄₀
		At 100 °C	At 250 °C	
Succinimide	1,5	55,5	43,5	0,51
C-5A	3,0	56	44,5	0,49

The received results show that an additive received on the basis of OE and on the basis of C-5A on an indicator «D» are practically equal. It is necessary to notice, that mass concentration of an additive on the basis of OE in the examinee oil a little bit lower, than of C-5A and a bit different from each other in stabilizing properties and correspond to additive C-5A with adherence to concentration.

4.3.3. Estimation of detergency of engine oils

Detergent properties are estimated with the help of State Standard 5726-53 method and are shown in Table 4.4.

Table 4.4

Characteristics of detergency

Additives	Oil Content, % mass.	detergency, in points
Succinimide	1,5	0,5
C-5A	3,0	1

Detergent properties of received additive are characterized by higher characteristics, with lower concentrations.

4.3.4. Estimation of detergency in automobile gasoline 92

The results of an estimation of efficiency of detergency of succinimide additives in automobile gasoline 92(octane number) are shown in Table 4.5

Table 4.5

Norm	Contamination, in points	Mass deposit on valve, mg
Gasoline	8,8	85
Gasoline + 0,05 % Succinimide	9,5	22
Gasoline + 0,08 % Succinimide	9,7	19
Gasoline + 0,1 % Succinimide	9,8	16

4.3.5. Influence of succinimide on low-temperature properties of diesel fuel

The results of an estimation of efficiency depressor properties of succinimide additive in diesel fuel are shown in Fig. 4.5.

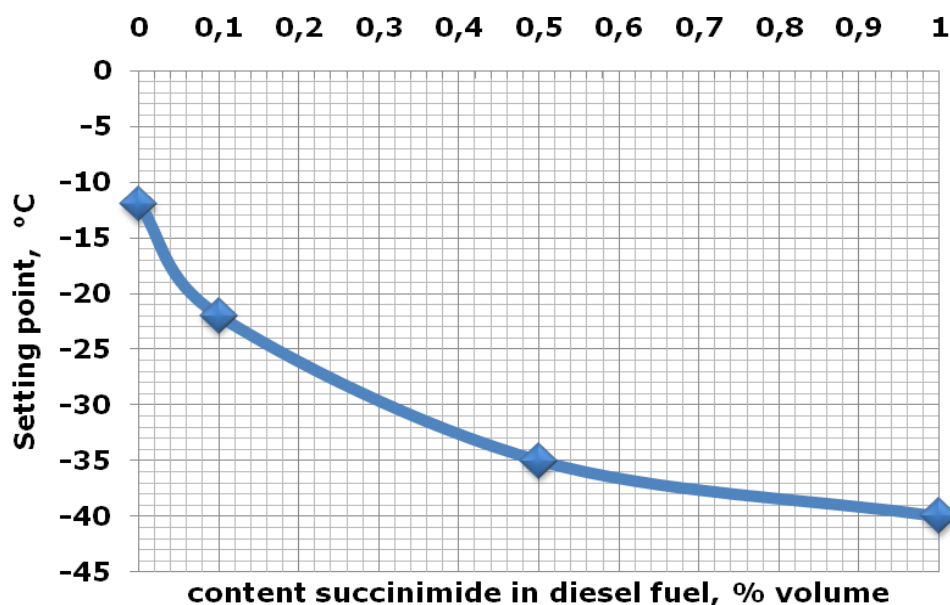

Figure 4.5. Dependence of setting point on the content of additive on a basis of succinimide and diesel fuel

As it is seen from Fig. 4.5, with increase of the content of a succinimide-based additive the temperature of hardening diesel fuel consistently decreases. With 0,5 % content low-temperature properties of summer diesel fuel conform to State Standard for winter diesel fuel - the setting point decreases to minus 35 °C.

4.4. Conclusion on head

We have developed three types of additives:

1. Ignition promoters:

– The increase of the content of additive CEA-1 in diesel fuel leads to increase of its cetane number.

– Developed additive CEA-1 leads to the increase in WSD of fuel, that is to the decrease of greasing ability.

– Use of additive CEA-1 can cause necessitate using wear-resistant additives.

2. Wear-resistant:

Maximum decrease of WSD is observed with use of an additive WR-3. With the content of 0,01 % of this additive in test diesel fuel the decrease of WSD on 31 % is observed.

3. There were done the researches of the impact of succinimide additives on low-temperature properties. This additive allows to receive winter diesel fuel with a dosage 0,5% of the given additive.

Thus JSC "Salavatnefteorgsintez" has technical possibility of the organisation of manufacturing of a multifunctional additive to diesel fuel on the basis of the developed additives: ignition promoters, wear-resistant, additives improving low-temperature properties. Moreover one part of reagents is developed at JSC "Salavatnefteorgsintez", the other part needs to be bought.

5. Conclusion and prospects

Receiving diesel fuel with the improved ecological and operational characteristics is connected with using the developed additives:

1. Additive:

We have developed additives of the following functional purpose:

– The promotor of ignition CEA-1. The given additive has been received on the basis of a by-product developed by JSC «Salavatnefteorgsintez». It is shown, that additive use allows to raise cetane number of test of diesel fuel by 6 points.

Disadvantage of additive CEA-1 is decrease in greasing ability of diesel fuel. The using of additive CEA-1 can necessitate using wear-resistant additives.

Further researches will consist in concentration of active component of given additive with the aim of decrease of its discharge intensity, and also in decrease of negative impact of additive CEA-1 on greasing ability of diesel fuel.

– Wear-resistant additives. There were developed wear-resistant additives, AW-1, AW-2, AW-3. The active components of the given additives are fat acids C_{17} - C_{22} . Maximum decrease of WSD is observed with the use of an additive AW-3. With the content of 0,01 % volumetric of this additive in test DF decrease of WSD on 31 % is observed.

Wear-resistant additive AW-3 has shown high efficiency and can be recommended for use at JSC «Salavatnefteorgsintez».

– The additives improving low-temperature properties. Influence researches of succinimide additives on low-temperature properties have been done. With the content of 1 % volumetric decrease of temperature of hardening from minus 12 to minus 40 °C is observed. Using of the given additive allows to receive winter diesel fuel from summer one by adding 0,5 % volumetric of additives.

The given additive can be made of components, part of which is developed by JSC «Salavatnefteorgsintez». Further researches consist in defining the possibility of the organisation of manufacture of the given additive on existing objects of JSC «Salavatnefteorgsintez».

Thus, on JSC «Salavatnefteorgsintez» there is a technical possibility of the organisation of manufacture of a multifunctional additive to diesel fuel on the basis of

the developed additives: ignition promoters, wear-resistant additives, the additives improving low-temperature properties.

Moreover one part of reagents is developed on JSC "Salavatnefteorgsintez", the other part needs to be bought.

2. Dopants.

We suggest using the following products as the dopants to diesel fuel:

– Rapeseed oil. The numerous researches of DF, containing RO, show, that its maximum content in fuel makes up 5 % volumetric. However, taking into account variability of physical and chemical characteristics of base DF and RO admissible content of RO in fuel can essentially decrease.

Thus, use of RO as an additive to DF will not allow to increase essentially resources of DF and can be used, in our opinion, for improving some characteristics of diesel fuel. For example, it has been shown, that adding 1 % mass of RO allows lowering WDS tests DF JSC «Salavatnefteorgsintez» by 54 %.

– Ethers of rapeseed oils. We have obtained an additive DERO. As initial components there were used rapeseed oil and bottom of butyl alcohols manufactured by JSC «Salavatnefteorgsintez». It is shown, that the maximum concentration of the given additive in diesel fuel makes 10 % volumetric. With the given concentration in diesel fuel the characteristic «iodic number» has reached the maximum size restricted by State Standard 305-82. The further researches will consist in improving technology of obtaining the additive with the purpose of increasing its maximum content in diesel fuel.

Thus, application of additive DERO will allow not only to improve operational and ecological indicators, but also to increase resources, diesel fuel made by JSC «Salavatnefteorgsintez».

References

1. The green book of Russia: Part II.-b. ,1994. - pp. 21-22.
2. Nomura H. Influence of quality of diesel fuel on the maintenance of harmful substances in exhaust gases of diesel engines (express information) // Sulfurs. Oil refining and petrochemistry, 1992. № 15. pp. 17-22.
3. Lindsay R. Problems of preservation of the environment at operation of the diesel engine (express information) // Sulfurs. Oil refining and petrochemistry, 1993. №12. pp. 20-25.
4. Emissions of firm particles with the fulfilled gases of petrol and diesel engines in Europe. (Processing of hydrocarbons) // Oil and gas technologies, 1998. pp. 56-47.
5. Кулиев А.М. Химия и технология присадок к маслам и топливам. М.: Химия, 1985. 312 с.
6. Данилов А.М. Применение присадок в топливах. М.: Мир, 2005. – 288 с.
7. Марков В.А., Баширов Р.М., Габитов И.И. Токсичность отработавших газов дизелей. М.: МГТУ им. Н.Э. Баумана, 2002. – 376 с.
8. Ахметов С.А. Экологическая химмотология топлив и масел. – Уфа: УГНТУ, 2008.– С. 99.
9. Kozlov A.V., Terenchenko A.S., Sister V.G, Ivannikova E.M, Yamchuk A.I. Efficiency analysis of efficiency of of biodiesel fuel usage in full life cycle // Khimicheskoe i Neftegazovoe Mashinostroenie, 2009. №7, С. 45-47.
10. Wilharm Th., Bernath J., Васильев И.П.. Разработка требований к растительным маслам как топливам для дизелей // Энерготехнологии и ресурсосбережение, 2009. №5, С. 16-23.
11. Shajahmetov I.T., Hasanov R. F, etc. Cultivation summer rape on seeds in Bashkortostan and use variants rape's oils as motor fuel. Ufa, 2008. p. 50.
12. Митусова Т.Н., Полина Е.В., Калинина М.В. Современные дизельные топлива и присадки к ним. Киев: Техника, 2002. 63 с.
13. Ахметов С.А. Технология глубокой переработки нефти и газа. Уфа : изд-во "Гилем", 2002. 672 с.
14. Данилов А.М. Введение в химмотологию. М.: Техника, 2003. 464 с.
15. Гальперин А.Е. Производство присадок к моторным и трансмиссионным маслам. М.: Химия, 1974. 196 с.

16. Капустин В.М. Нефтяные и альтернативные топлива с присадками и добавками. М.: Издательство "КолосС", 2008. 232 с.

17. European patent EP 605857 CI. With. 10 L 1/02 Wenderoth Bernd; Thomas Juergen "Low sulphur mineral diesel fuel oil", 5 Oct. 1994. - p. 7.

18. Patent PCT Int. Appl. WO98 34998 CI. With 10 L 1/08, Cook B. Randall; Berlowitz J, Diesel fuel additive for improving cetane number, lubricity and stability, 13 Aug. 1998. With 23.

19. The patent of USA US 5746785 CI. 44-443; With. 10 L 1/18, Moulton David S.; Naegeli David W. Preparation of a diesel fuel having improved qualities, 5 May 1998. - C. 4.

20. Patent PCT Int. Appl. WO 96 26994 CI. C. 10 L 1/08, Fara Carlos S.; Caprotti Rinaldo. Fuel oil composition, 13 Sep. 1996. - p. 7

21. The patent of Japan JP1095989 [9895,989] CI. With. 10 L 1/08, Komatsu Y.; Takenaga N.; I. High-quality low sulphur gas oil composition, 13 Apr. 1998. - with 7

22. The patent of Japan JP09 324185 [97,324,185) C1. C10 L 1/18, ArataShinichi, Matsuui Yuichi. Antiwear agents for fuel oils and fuel oil compositions, 16 Dec. 1997. - With 6.

23. European patent EP 635558 C1. With 10 L 1/18, Giavazzi Fulvio, Panarello Febronio. Gas oil composition for motor vehicles, such as diesel fuel, containing a lubricity improver based on bio-diesel fuels, 25 Jan 1995.

24. European patent EP 773278 CI. With 10 L 1/18, Quigley Robert Fuel additive, 4 May 1997. - With 10.

25. The patent of Czechia Czech. CS 275894 CI. With 10 L 1/18, Bratsky Daniel, Kostolanyi Peter. Antiwear additive for fuels for diesel or jet propulsion engines, 18 Mart. 1992. - with 7.

26. Patent PCT Int. Appl. WO 99 15607 CI. With 10 M 159/12, Caprotti Rinaldo, Ledere Christopher. Reaction products of fatty acid dimers with epoxides as lubricity additives for fuel oils and diesel fuels, [Apr. 1999. - With 2].

27. Patent PCT Int. Appl. WO 98 35000 CI. With 10 L 1/18, Berlowitz Paul J., Cook B. Randall, Wittenbrink Robert J. «Alcohols as lubricity additives for distillate fuels», 13 Aug. 1998.-C. 16.

28. Patent PCT Int. Appl. WO 99 33938 CI. With 10 L 1/18, Eber Daniele, Germaud Laurent, Maldonado Paul. Fuel additive, 8 Jul. 1999. - C. 23.

29. Patent PCT Int. Appl. WO 95 21904 CI. With 10 L 1/18, Hoehn Arthur, Funke Hans. Preparation of carboxylic acid esters and their use as fuel or lubricant additives, 17 Aug. 1995.-with 16.

30. The patent of Japan JP 10 110175 [98,110,175] CI. With 10 L 1/18, Hashimoto Jiro Low-sulphur gas oil compositions and oiliness improves for them, 18 Apr. 1998. - C. 6.

31. The patent of Japan JP 09 272870 [97,272,880] CI. With 10 L 1/18, Nahada J., Imai T, Nomura T, Fuel oil compositions, 21 Oct. 1997. - With 6.

32. Patent PCT Int. Appl. WO 96 18707 CI. With 10 L 1/18, Davies B. W, Caprotti R. Fuel oil compositions, 20 Jim. 1996. - With 25.